

JVC



A / V CONTROL AMPLIFIER

KV-RA2

ENGLISH

AMPLIFICADOR DE CONTROL DE A / V

KV-RA2

ESPAÑOL

AMPLIFICATEUR DE COMMANDE A / V

KV-RA2

FRANÇAIS

BBE[®]

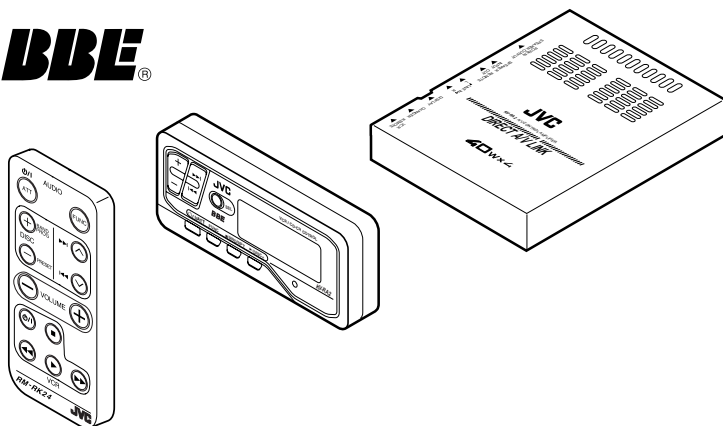

For installation and connections, refer to the separate manual.
Para la instalación y las conexiones, refiérase al manual separado.
Pour l'installation et les raccordements, se référer au manuel séparé.

INSTRUCTIONS

MANUAL DE INSTRUCCIONES
MANUEL D'INSTRUCTIONS

For customer Use:

Enter below the Model No. and Serial No. which are located on the top or bottom of the cabinet. Retain this information for future reference.

Model No. _____

Serial No. _____

PIM15090M

[J]

Thank you for purchasing this JVC product. Please read these instructions carefully before starting operation to obtain optimum performance and a longer service life from the unit.

INFORMATION (For U.S.A.)

This equipment has been tested and found to comply with the limits for a Class B digital device, pursuant to Part 15 of the FCC Rules. These limits are designed to provide reasonable protection against harmful interference in a residential installation. This equipment generates, uses, and can radiate radio frequency energy and, if not installed and used in accordance with the instructions, may cause harmful interference to radio communications. However, there is no guarantee that interference will not occur in a particular installation. If this equipment does cause harmful interference to radio or television reception, which can be determined by turning the equipment off and on, the user is encouraged to try to correct the interference by one or more of the following measures:

- Reorient or relocate the receiving antenna.
- Increase the separation between the equipment and receiver.
- Connect the equipment into an outlet on a circuit different from that to which the receiver is connected.
- Consult the dealer or an experienced radio/TV technician for help.

BEFORE USE

* *For safety....*

- *Do not raise the volume level too much, as this will block outside sounds, making driving dangerous.*
- *Stop the car before performing any complicated operations.*

* *Temperature inside the car....*

If you have parked the car for a long time in hot or cold weather, wait until the temperature in the car becomes normal before operating the unit.

CONTENTS

FEATURES	2
LOCATION OF CONTROLS	3
BASIC OPERATIONS	4
CD CHANGER OPERATIONS	5
Playing CDs	5
Selecting CD playback modes.....	6
VCR OPERATIONS.....	7
LISTENING TO YOUR CAR RECEIVER	8
SOUND ADJUSTMENT	9
MAINTENANCE.....	10
TROUBLESHOOTING	11
SPECIFICATIONS	12

FEATURES

The KV-RA2, when used with a JVC CD changer and VCR, provides high quality and high-powered sound from your existing receiver.

LOCATION OF CONTROLS



Display unit

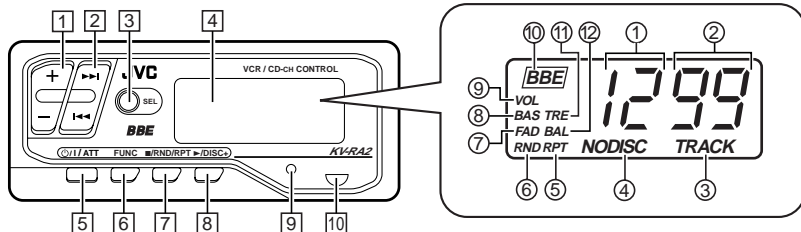

- 1 Volume button (+, -): Adjusts the volume level or sound adjustment level.
- 2 ►►, I◄◄ button: Used for various CD playback modes.
Fast-forwards or rewinds a video tape.
- 3 SEL (select) button: Calls up the sound adjustment mode.
- 4 Display
 - 1 Disc number indicator (1–12)
 - 2 Track number indicator (1–99)
 - 3 TRACK indicator
 - 4 DISC/NO DISC indicator
 - 5 RPT (repeat) indicator
 - 6 RND (random) indicator
 - 7 FAD (fader) indicator
 - 8 BAS (bass) indicator
 - 9 VOL (volume) indicator
 - 10 BBE indicator
 - 11 TRE (treble) indicator
 - 12 BAL (balance) indicator
- 5 ϕ /I/ATT button: Turns the power on or off.
Drops the volume in a moment.
- 6 FUNC (function) button: Selects a source (CD changer, VCR or car receiver (AUX)).
- 7 ■/RND/RPT button:
 - While playing a CD : Performs random play or repeat play.
 - While playing a video tape: Stops video playback.
- 8 ►/DISC + button:
 - While playing a CD: Plays the next disc.
 - While VCR is selected as the source: Plays a video tape.
- 9 Microcomputer reset button
- 10 Remote sensor

Remote controller

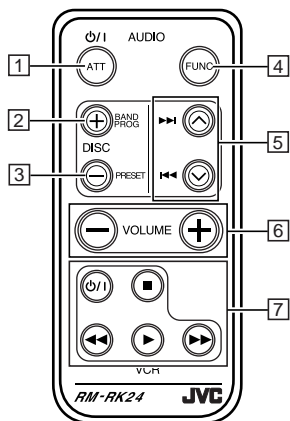

- 1 ϕ /I/ATT button:
 - Turns the power on or off.
 - Drops the volume in a moment.
- 2 DISC + (BAND PROG) button:
 - Plays the next disc.
 - Does not function as a BAND or PROG button.
- 3 DISC - (PRESET) button:
 - Plays the previous disc.
 - Does not function as a PRESET button.
- 4 FUNC (function) button:
 - Selects a source (CD changer, VCR or car receiver (AUX)).
- 5 ►►, I◄◄ buttons:
 - Used for various CD playback modes.
 - Do not function as \blacktriangle or \blacktriangledown buttons.
- 6 Volume buttons (+, -):
 - Adjust the volume level or sound adjustment level.
- 7 ϕ /I : Turns on or off the VCR.
 - ■ : Stops playing a video tape.
 - ◄◄ : Rewinds a video tape.
 - ►► : Starts playing a video tape.
 - ►►► : Fast-forwards a video tape.



BASIC OPERATIONS

ENGLISH

Before operating this unit, see the instructions supplied with the other components connected to this unit.

Display unit

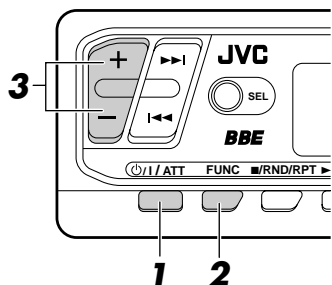

Remote controller

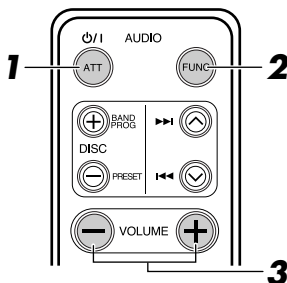

When using the remote controller, **point it toward the remote sensor on the display unit**, then press buttons gently and firmly.

1 Display unit

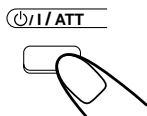

Remote controller



Press **⏻/ATT**.
The unit turns on.

2

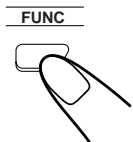

Press **FUNC** (function).
Each time you press **FUNC**, the source changes as follows:

→ **CD changer** → **VCR** → **AUX**
(Car receiver)

To operate the CD changer, see page 5.
To operate the VCR, see page 7.
To operate the car receiver, see page 8.

3

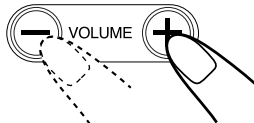
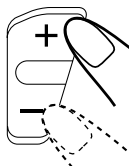

Adjust the volume with the volume buttons (+, -).
Volume level appears.

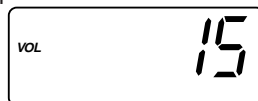

4 Adjust the sound as you want. (See page 9.)

To drop the volume in a moment

Press **⏻/ATT** briefly.

To resume the previous volume level, press the same button briefly again.

To turn off the power

Press **⏻/ATT** for more than 1 second.

CD CHANGER OPERATIONS



You can connect one of the JVC CD changer CH-X series.

Playing CDs

Display unit

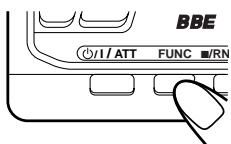

Remote controller

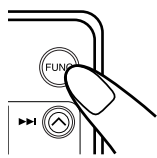

Press FUNC (function) repeatedly until the disc number and the track number appear on the display.

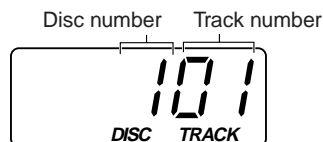

The CD changer starts playing from the first track of the first disc.

Note:

When all the tracks on the first disc have been played, the second disc starts playing automatically from the first track.

To stop CD playback

- Change the source by pressing FUNC.
- Press and hold ⏻/ATT for more than 1 second.

To go to the next disc

Display unit

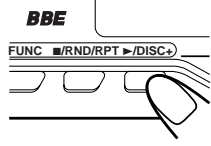

Remote controller

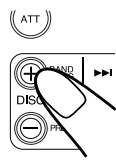

Press DISC +.

Each time you press DISC +, the disc number increases in sequence.

Note:

When you select a CD, its disc number flashes on the display.

To go to the previous disc

Remote controller only

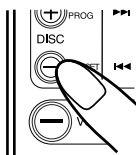

Press DISC -.

Each time you press DISC -, the disc number decreases in sequence.



To go to the next or previous tracks

Display unit

Remote controller

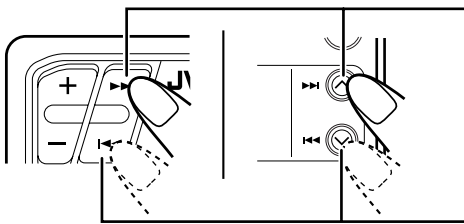

Press **▶▶** briefly while playing a CD, to go to the beginning of the next track. Each time you press the button consecutively, the beginning of succeeding tracks is located and played back.

Press **◀◀** briefly while playing a CD, to go to the beginning of the current track. Each time you press the button consecutively, the beginning of previous tracks is located and played back.

To fast-forward or reverse the track

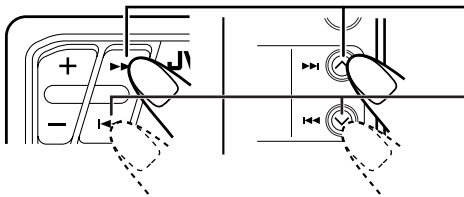

Press and hold **▶▶** while playing a CD, to fast-forward the track.

Press and hold **◀◀** while playing a CD, to reverse the track.

Selecting CD playback modes

To play the tracks at random

Display unit only

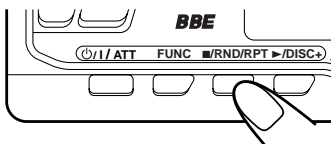

Each time you **press** **■**/RND/RPT while playing a CD, CD random play mode changes as follows.



Mode	RND indicator	Plays at random
RND1	Lights	All tracks of the disc being played.
RND2	Flashes	All tracks of all discs inserted in the magazine.

To play the tracks repeatedly

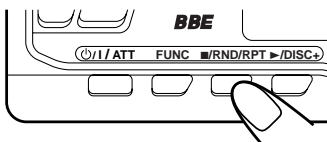

Each time you **press and hold** **■**/RND/RPT while playing a CD, CD repeat play mode changes as follows.



Mode	RPT indicator	Plays repeatedly
RPT1	Lights	The track being played.
RPT2	Flashes	All tracks of the disc being played.

VCR OPERATIONS



You can connect a JVC VCR (ex. KZ-V10).

Before you start...

- Turn on a monitor set or TV set connected to the VCR and set it to its external input to watch picture from the VCR.
- Insert a video tape into the VCR.

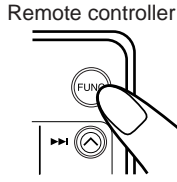
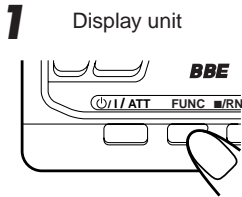

Press FUNC (function) repeatedly until "VCR" appears on the display.

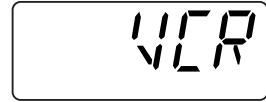

2 Remote controller only



Press **⏻**.
The VCR turns on.

3

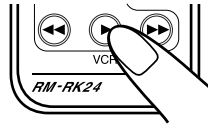

Press **▶**.
The VCR starts playing a video tape.

Note:

Even if you change the source to CD changer or car receiver (AUX) while watching a video tape, VCR playback continues, but the sound does not come out of the speakers.

To stop video playback

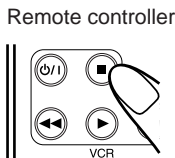
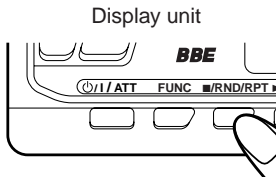

Press **■**.

To fast-forward or rewind a video tape

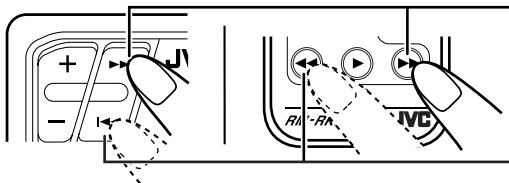

Press **▶▶** or **▶▶▶**.

Press **◀◀** or **◀◀◀**.

Note:

If you press the buttons while watching the video tape, you can search for a particular scene by fast-forwarding or rewinding.

To turn off the VCR

Press **⏻**.

Notes:

- Even if you are selecting CD changer or car receiver (AUX) as the source, you can operate the VCR by using the buttons of the remote controller.
- Use the remote controller supplied with the VCR for operations except the above operations. (See the instructions supplied with the VCR.)



LISTENING TO YOUR CAR RECEIVER

ENGLISH

1 Turn on your car receiver.

2 Display unit

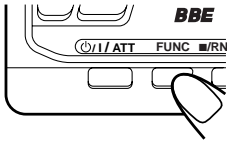

Remote controller

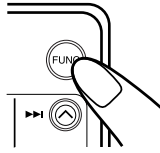

Press FUNC (function) repeatedly until “AUX” appears on the display.



3 Operate your car receiver.

For details, refer to the instructions supplied with the car receiver.

Note:

*Do not adjust the sound (bass, treble, fader and balance) on your car receiver.
When you want to adjust the sound, see page 9.*

SOUND ADJUSTMENT



You can adjust the sound characteristics to your preference.

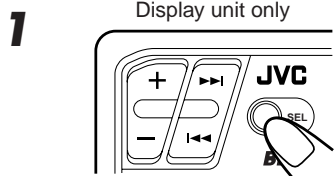

Press SEL (select).

Each time you press SEL, the sound adjustment mode changes as follows.



Indication	To do:	Range
VOL (volume)	Adjusts the volume.	00 (min.) — 50 (max.)
BAS*(bass)	Adjusts the bass.	-06 (min.) — +06 (max.)
TRE*(treble)	Adjusts the treble.	-06 (min.) — +06 (max.)
FAD**(fader)	Adjusts the front and rear speakers balance.	R06 (rear only) — F06 (front only)
BAL (balance)	Adjusts the left and right speakers balance.	L06 (left only) — R06 (right only)
BBE*	See "What is BBE?" below.	on — oFF

* Bass sound (BAS), treble sound (TRE) and BBE can be set for CD changer, VCR and car receiver (AUX) separately.

** When you are using a two-speaker system, set fader (FAD) to "00."

Notes:

- Normally the volume level can be adjusted by pressing the volume buttons. (See page 4.)
- If your car receiver has the same sound adjustment modes as listed above, fix them to the center positions or to "OFF" positions.
- For the volume level on your car receiver, fix it to such a level that you can adjust the volume level properly only with the volume buttons of this unit.

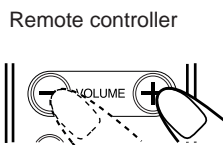
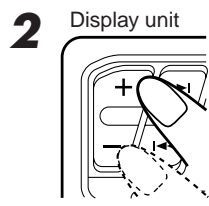

Adjust the level with the volume buttons.

What is BBE?

The BBE function restores the brilliance and clarity of the original live sound in recording, broadcasts, etc.

When a speaker reproduces sound, it introduces frequency-dependent phase shifting, causing high-frequency sounds to take longer to reach the ear than low frequency sounds. The BBE function adjusts the phase relationship between the low, mid and high frequencies by adding a progressively longer delay time to the low and mid frequencies, so that all frequencies reach the listener's ears at the proper time.

In addition, the BBE function boosts low and high frequencies, which loudspeakers tend to be less efficient in reproducing, through dynamic, program-driven augmentation. When combined with the phase compensation feature, the resulting sound has a clearer, more finely detailed "live" presence.

Under license from BBE Sound, Inc.

BBE® is a trademark of BBE Sound, Inc.



MAINTENANCE

ENGLISH

Battery replacement

When the remote-controllable range becomes narrower, the battery should be replaced. (Battery life is about 1 year with normal use.)

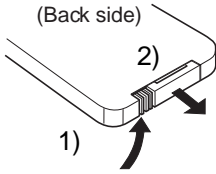

1. Remove the battery case.

- 1) Push in the direction indicated by the arrow with your right hand thumbnail.
- 2) Remove the battery case.

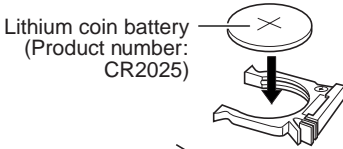

2. Replace the battery.

Put the battery in the case with the + side facing upwards.

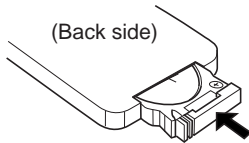

3. Return the battery case.

Insert the battery case. Push it in until you hear a clicking sound.

WARNING:

- Store the battery in a place which children cannot reach. If a child accidentally swallows the battery, immediately consult a doctor.
- Do not recharge, short, disassemble or heat the battery or dispose of it in a fire; otherwise, the battery might give off heat, crack or start a fire.
- Do not leave the battery together with other metallic materials; otherwise, the battery might give off heat, crack or start a fire.
- When throwing away or saving the battery, wrap it in tape to insulate; otherwise, the battery might give off heat, crack or start a fire.
- Do not poke the battery with tweezers or similar tools; otherwise, the battery might give off heat, crack or start a fire.

How to reset your unit

When this unit does not work at all, reset the unit.

Put a straight thin stick like a ball-point pen into the microcomputer reset button. This will reset the built-in microcomputer.

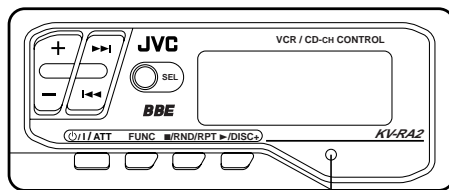

Microcomputer reset button

TROUBLESHOOTING

What appears to be trouble is not always serious.
Check the following points before calling a service center.

Symptoms	Causes	Remedies
<ul style="list-style-type: none"> • Sound cannot be heard from the speakers. 	The volume level is turned to the minimum level.	Adjust it to the optimum level.
	When you are listening to the car receiver (AUX), the volume level is set to the minimum level on the car receiver.	Adjust the volume on the car receiver.
	Connections are incorrect.	Check the cords and connections.
<ul style="list-style-type: none"> • Sound is distorted while you are listening to the car receiver (AUX). 	The sound adjustment modes on your car receiver are used.	Fix the sound adjustment to the center positions or to "OFF" positions on the car receiver.
<ul style="list-style-type: none"> • "NO DISC" appears on the display. 	No CD is in the magazine.	Insert CDs into the magazine.
	CDs are inserted incorrectly.	Insert them correctly.
<ul style="list-style-type: none"> • "R-8" appears on the display. 	This unit is not connected to a CD changer correctly.	Connect this unit and the CD changer correctly and press both the reset buttons of this unit and the CD changer.
<ul style="list-style-type: none"> • "R-1" to "R-7" appears on the display. 	_____	Press both the reset buttons of this unit and the CD changer.
<ul style="list-style-type: none"> • Remote controller does not work. 	The battery is exhausted.	Replace the battery.
	Battery polarity (+, -) is reversed.	Put the battery correctly.
	The operation is incorrect.	Point the remote controller toward the display unit.
<ul style="list-style-type: none"> • This unit does not work at all. • The CD changer does not work at all. 	The built-in microcomputer may function incorrectly due to noise, etc.	Put a straight thin stick like a ball-point pen into the microcomputer reset button. (See page 10.)

* For CD changer, see the instructions supplied with the CD changer.

SPECIFICATIONS

AMPLIFIER SECTION

Maximum power output:

Front: 40 watts per channel

Rear: 40 watts per channel

Continuous power output (RMS):

Front: 15 watts per channel into 4 Ω ,
40 to 20,000 Hz at no more
than 0.8% total harmonic
distortion.

Rear: 15 watts per channel into 4 Ω ,
40 to 20,000 Hz at no more
than 0.8% total harmonic
distortion.

Load impedance: 4 Ω (4 to 8 Ω allowable)

Frequency response: 40 to 20,000 Hz

Line input sensitivity/Impedance:
0.5 V/20 k Ω

Speaker input sensitivity/Impedance:
4 V/1.5 k Ω

Signal-to-signal ratio: 70 dB

GENERAL

Power requirements:

Operation voltage:

DC 14.4 V (11 V – 16 V allowable)

Grounding system: Negative ground

Dimensions (W x H x D):

Amplifier unit: 200 x 162 x 30 mm
(7-7/8" x 6-7/16" x 1-3/16")

Display unit: 104 x 40 x 20 mm
(4-1/8" x 1-5/8" x 13/16")

Mass:

Amplifier unit: 750 g (1.7 lbs)

Display unit: 240 g (0.53 lbs)

Design and specification subject to change without notice.

If a kit is necessary for your car, consult your telephone directory for the nearest car audio speciality shop.



**Having TROUBLE with operation?
Please reset your unit**

**Refer to "How to reset your unit"
Still having trouble??**

USA ONLY

Call 1-800-252-5722

<http://www.jvcservice.com>

We can help you!

JVC

VICTOR COMPANY OF JAPAN, LIMITED